

REINFORCED CONCRETE MARKER
POST STAMPED WITH "V" AND
DISTANCE TO VALVE TO THE
NEAREST FOOT STENCILLED WITH
WHITE 2" NUMERALS

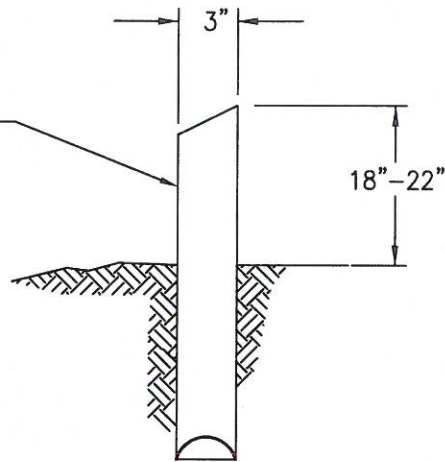

SIDE

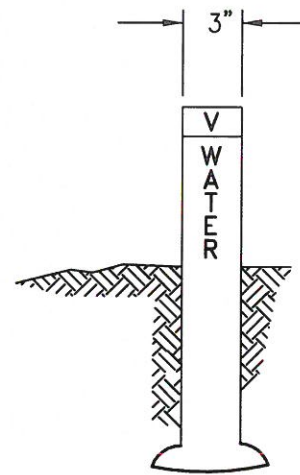

FRONT

VALVE MARKER POST

NOTES:

1. INSTALL AT ALL VALVES NOT LOCATED WITHIN PAVED AREA.
2. THE LETTER V AND THE WORD WATER SHALL BE CAST IN THE FACE OF THE MARKER FACING THE VALVE WITH THE DISTANCE TO THE VALVE PAINTED ON THE MARKER WITH WHITE ENAMEL PAINT.
3. PAINT THE ABOVE GROUND PORTION WITH 2 COATS OF BLUE MILLER PAINTS 13LW0054 OR BLUE RODDA PAINTS EV13D5870 OR EQUAL.
4. MARKERS SHALL BE DIRECT BURY.
5. 66" CARSONITE, HANSON TRI-FLEX, OR EQUAL MAY BE USED UPON APPROVAL BY THE DISTRICT.

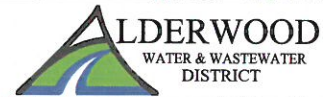

ALDERWOOD
WATER & WASTEWATER
DISTRICT

VALVE MARKER POST

DATE: 11-2015

DWG. WD-18

APPROVED BY: DLH
DISTRICT ENGINEER