

APPROVED METHOD OF
HYDRANT USE

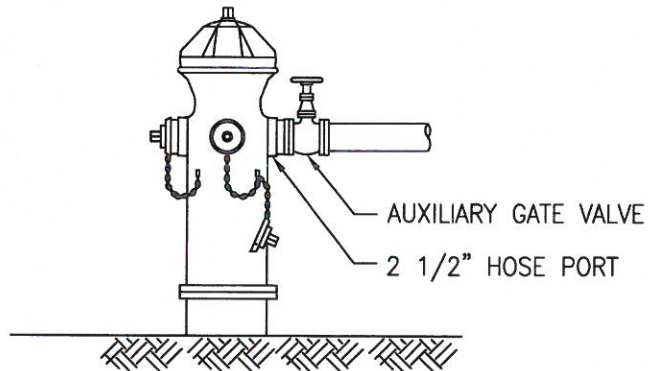

HYDRANT USE PROCEDURES

1. USER MUST HAVE A VALID "WATER USE PERMIT" FOR EACH VEHICLE, FROM THE DISTRICT IN THEIR POSSESSION. ONLY APPROVED/DESIGNATED FILLING HYDRANTS CAN BE USED FOR FILLING. CONTACT OPERATION AND MAINTENANCE FOR APPROVED FILLING HYDRANT LOCATIONS AND VEHICLE INSPECTION.
2. THERE SHALL BE AN ACCEPTABLE WASHINGTON STATE APPROVED AND TESTED "BACKFLOW ASSEMBLY" OR AN APPROVED AIR GAP.
3. OPENING AND CLOSING OF HYDRANT VALVE SHALL BE WITH AN ACCEPTABLE WRENCH TO RECEIVE THE 5-SIDED NUT AND SHALL BE DONE SLOWLY TO PREVENT EXCESSIVE PRESSURE SURGES ON THE WATER SYSTEM.
4. THERE SHALL BE AN AUXILIARY GATE VALVE ATTACHED TO THE 2-1/2 HOSE PORT OF THE HYDRANT PROVIDED BY PERMIT HOLDER.
5. THE HYDRANT VALVE SHALL BE FULLY OPENED AND THE WATER USE CONTROLLED EXCLUSIVELY BY THE AUXILIARY GATE VALVE.
6. THE AUXILIARY GATE VALVE SHALL BE OPERATED IN A SLOW MANNER TO PREVENT EXCESSIVE PRESSURE SURGES ON THE WATER SYSTEM.
7. WATER FROM HYDRANTS WITHIN THE DISTRICT CANNOT BE USED OUTSIDE OF THE DISTRICT BOUNDARIES. ANY VIOLATIONS ARE SUBJECT TO LOSS OF WATER USE PERMITS AND MONETARY FINE.
8. IF UNABLE TO OPERATE OR CLOSE THE HYDRANT PROPERLY, CALL THE DISTRICT IMMEDIATELY FOR ASSISTANCE - (425)787-0250.
9. DO NOT USE PRIVATELY OWNED HYDRANTS THAT ARE LOCATED WITHIN THE DISTRICT. NORMALLY, PRIVATE HYDRANTS WILL BE PAINTED WHITE.

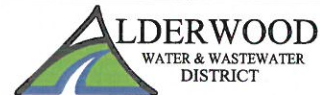

HYDRANT USE REQUIREMENTS

DATE: 11-2015

DWG. WD-8

APPROVED BY: _____ DLH _____
DISTRICT ENGINEER